



ASSEMBLY INSTRUCTION

ESKO QUEEN BED

ITEM CODE 70371

Imported by Amart Furniture Pty Ltd, Qld, Brisbane Australia.  
For any assistance with assembly or for missing parts please  
phone Amart Furniture , Customer Service Free call 1800 351  
084

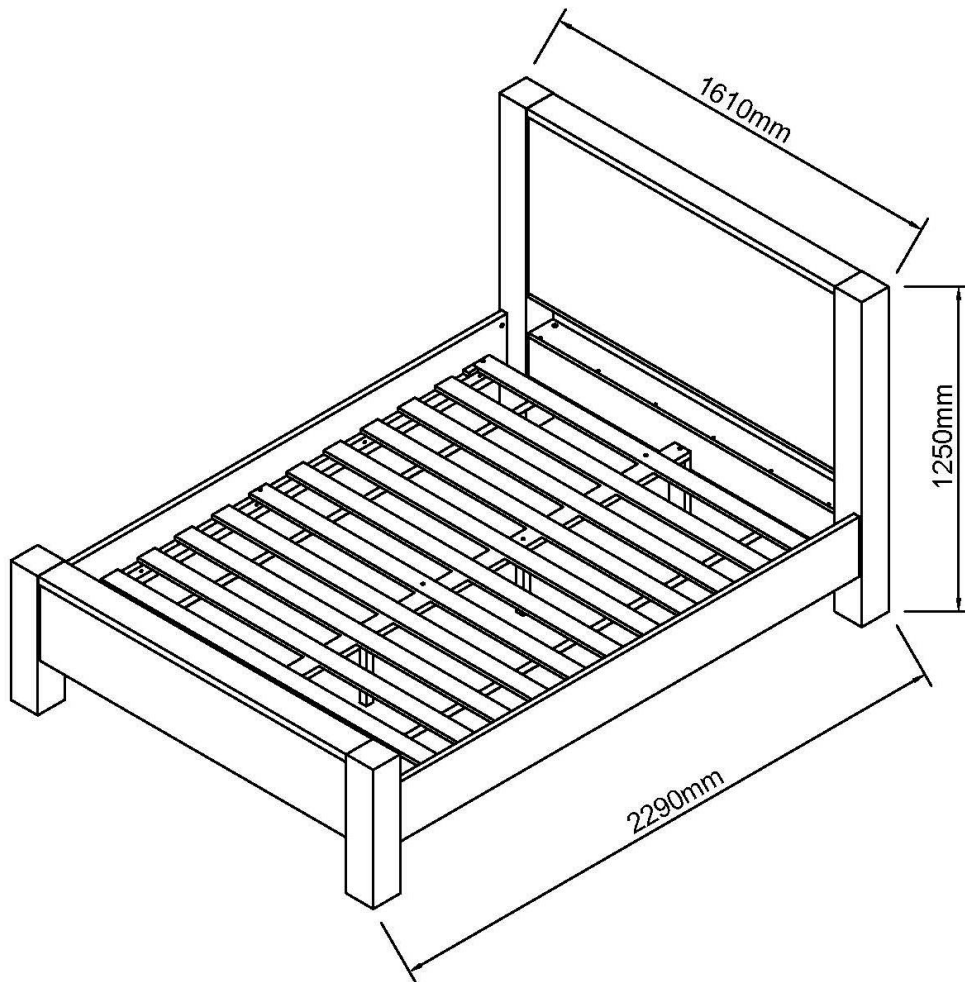



Imported by Amart Furniture Pty Ltd, Qld, Brisbane Australia.  
For any assistance with assembly or for missing parts please phone  
Amart Furniture, Customer Service Free call 1800 351 084

## PRE-ASSEMBLY PREPARATION

### Before you start:

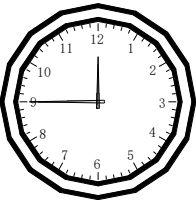
1. Choose a clean, level, spacious assembly area. Avoid hard surfaces that may damage the product
2. Take care when lifting. Product should be assembled as near as possible to the point of use
3. Ensure that you have all required contents for complete assembly
4. Always read the assembly instructions carefully before beginning assembly.
5. Keep all hardware parts and packaging out of reach of small children.
6. Do not over tighten the screws and bolts as this may damage the threads

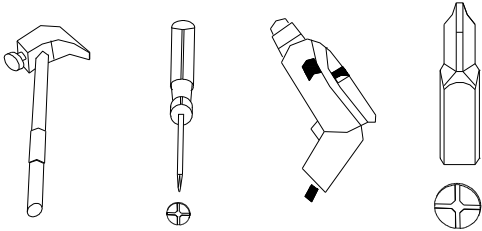
	
ALLOW 45 MINUTES	2 PEOPLE REQUIRED
	
TOOLS REQUIRED	

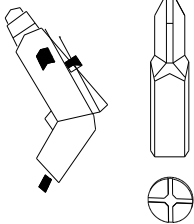





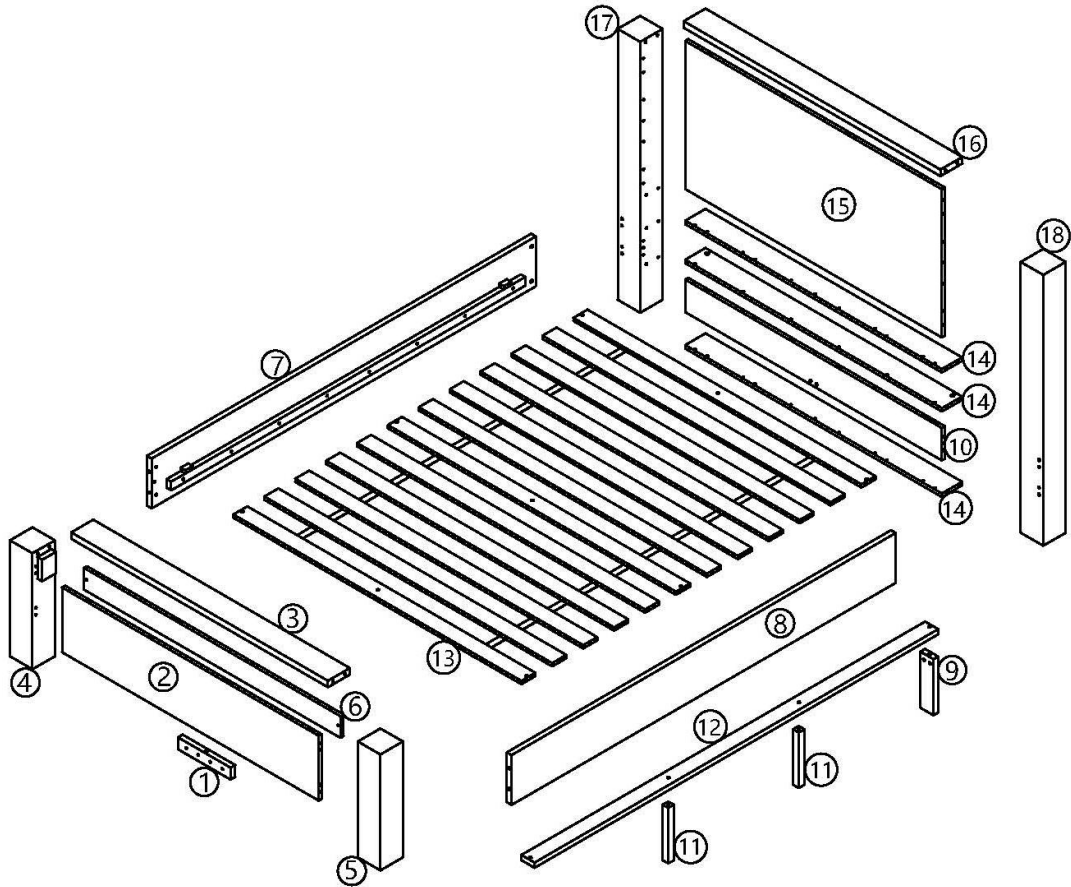





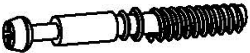

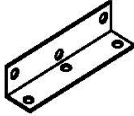

We recommend using a screwdriver to put this item together. However if you choose to use a power drill it must be used on **LOW SPEED (LOW TORQUE)** as too much pressure could damage the product

# PARTS LIST







1	<b>SUPPORT BAR</b>
2	FOOTBOARD
3	FOOTBOARD TOP
4	FOOTBOARD LEG
5	FOOTBOARD LEG
6	FOOTBOARD SUPPORT BOARD
7	SIDE RAIL
8	SIDE RAIL
9	SUPPORT LEG

10	<b>HEADBOARD SUPPORT BOARD</b>
11	SUPPORT LEG
12	CENTRE RAIL
13	SLATS
14	HEADBOARD SUPPORT BOARD
15	HEADBOARD
16	HEADBOARD TOP
17	HEADBOARD LEG
18	HEADBOARD LEG



<p>A. <math>\phi 15 \times 12</math></p>  <p>AX38</p>	<p>B. M7X53mm</p>  <p>BX38</p>	<p>C. <math>\phi 8 \times 40</math>mm</p>  <p>CX57</p>	<p>D. M5X30mm</p>  <p>DX9</p>
<p>E. M5X40mm</p>  <p>EX18</p>	<p>F. M6X20mm</p>  <p>FX12</p>	<p>G. M6X40mm</p>  <p>GX8</p>	<p>H.</p>  <p>HX20</p>
<p>I. L150</p>  <p>IX2</p>	<p>J. M4</p>  <p>JX1</p>	<p>K. M6X50mm</p>  <p>KX4</p>	<p>L. M8X150</p>  <p>LX4</p>
<p>M. M8X20</p>  <p>MX4</p>	<p>N. M5</p>  <p>NX1</p>	<p>O.</p>  <p>OX2</p>	<p>P. M4X15</p>  <p>PX4</p>

## STEP 1:

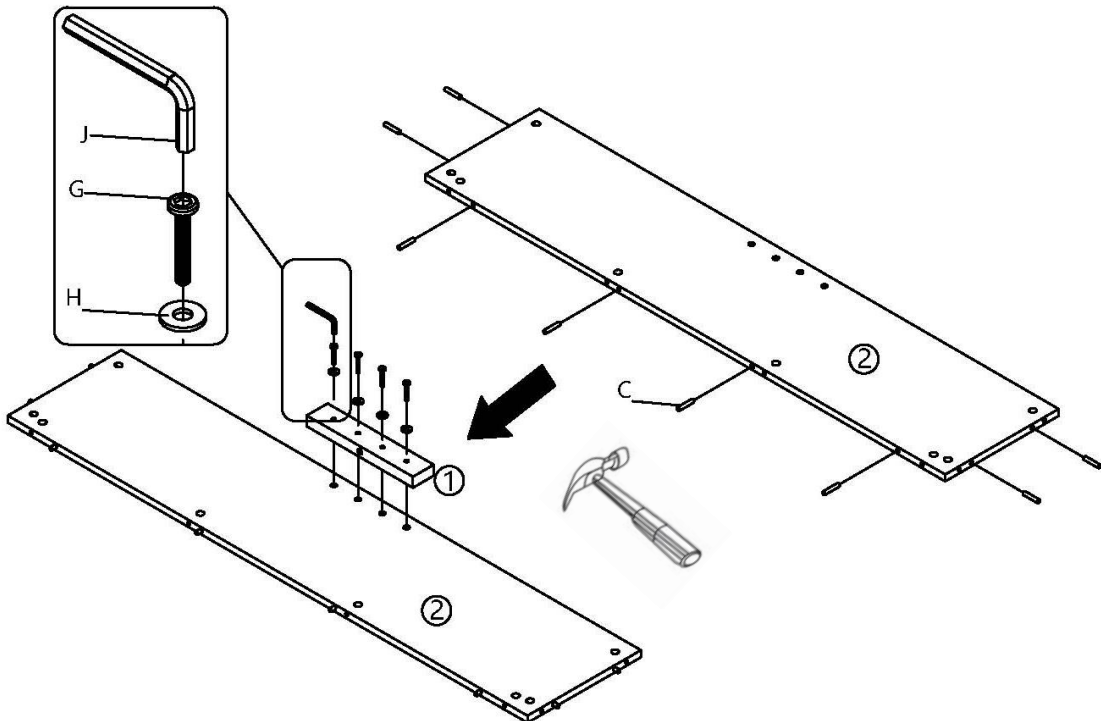
<p>C. <math>\phi 8 \times 40</math>mm</p>  <p>CX 8</p>	<p>G. M6X40mm</p>  <p>GX4</p>	<p>H.</p>  <p>HX4</p>	<p>J. M4</p>  <p>JX1</p>
---	--	--	---

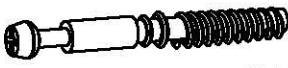

# STEP 2:

B. M7X53mm  BX8	C. $\phi$ 8X40mm  CX2
--	--

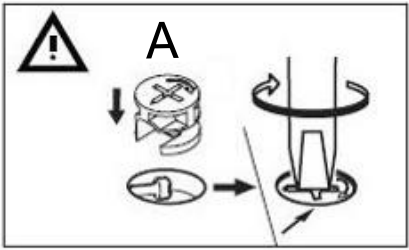
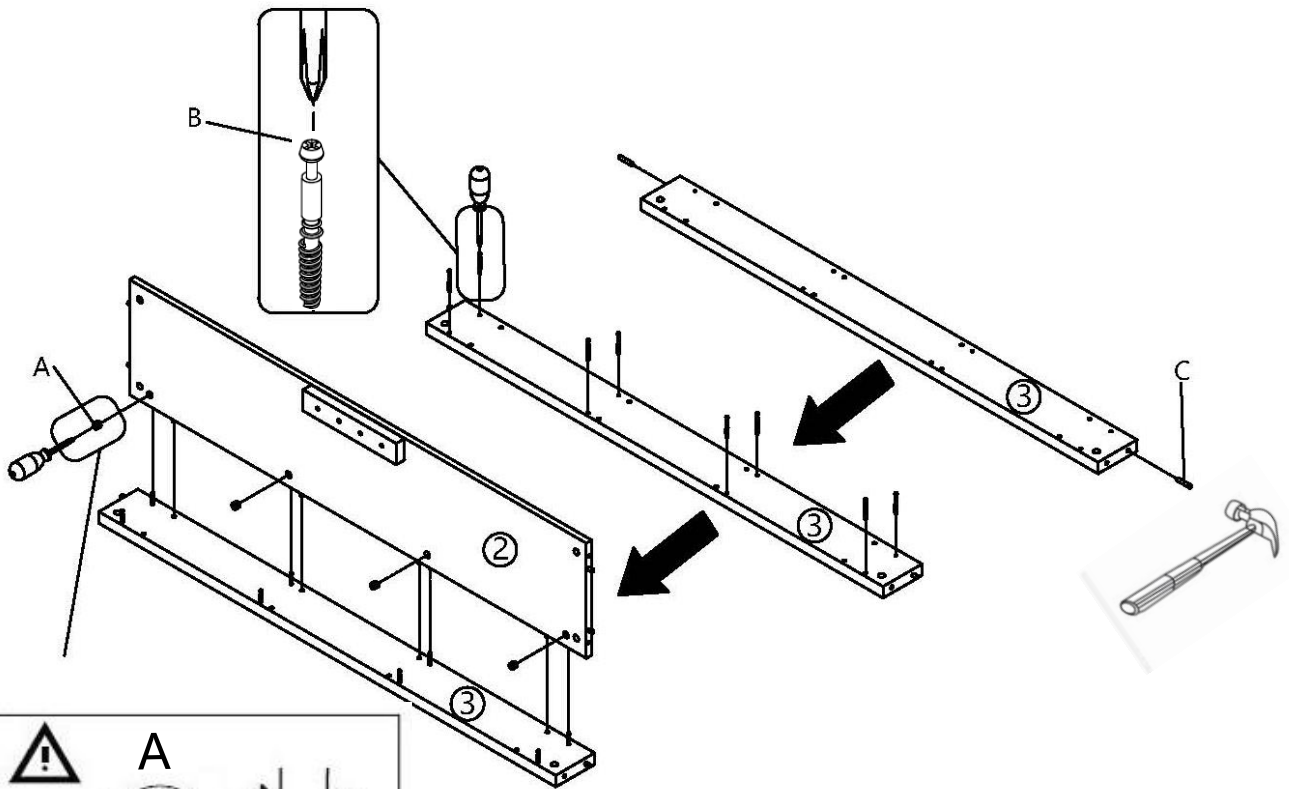

# STEP 3:

A.  $\varnothing 15 \times 12$



AX 6

B. M7X53mm



BX 6

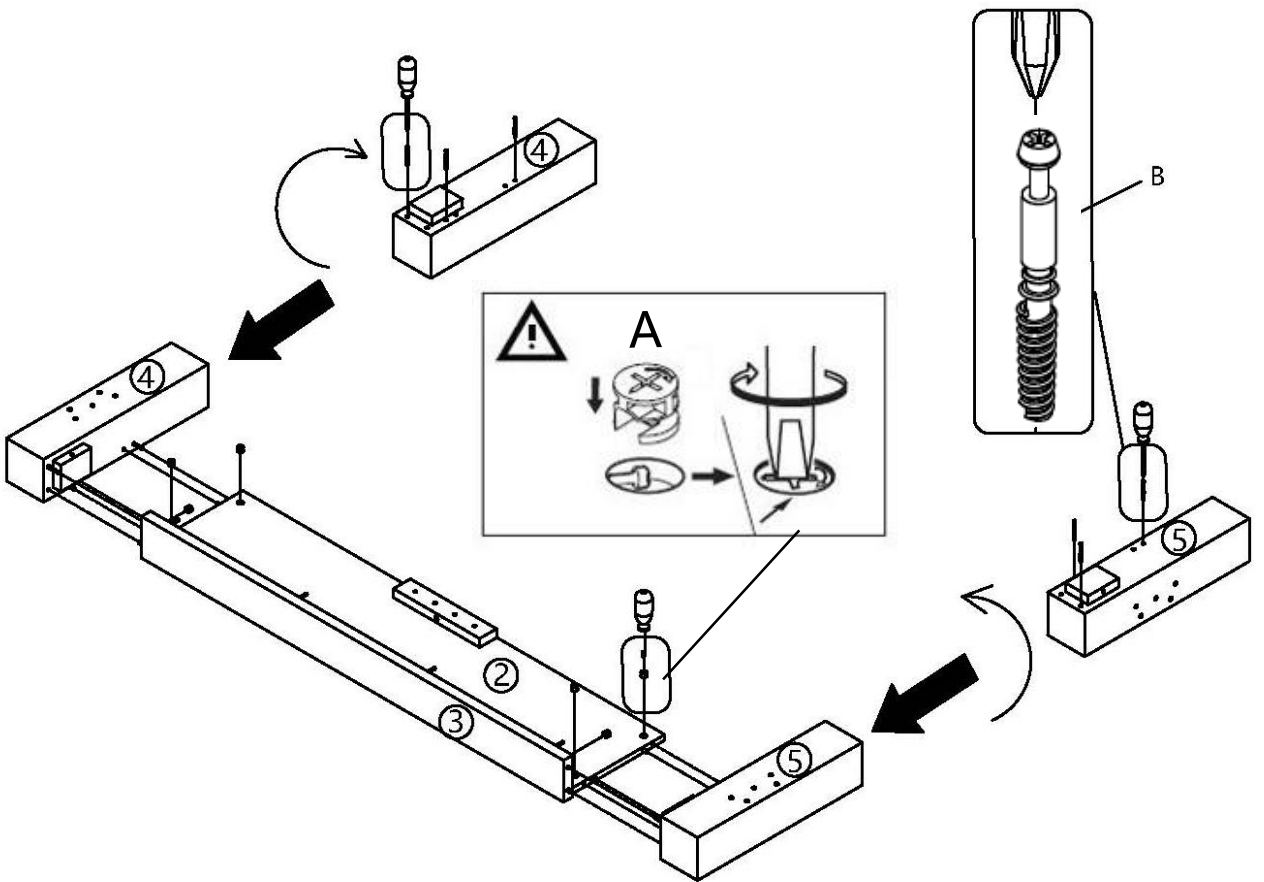

# STEP 4:

A.  $\phi 15 \times 12$



AX 4

C.  $\phi 8 \times 40 \text{mm}$



CX 4

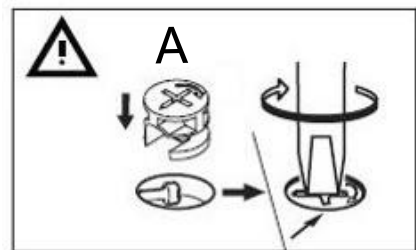
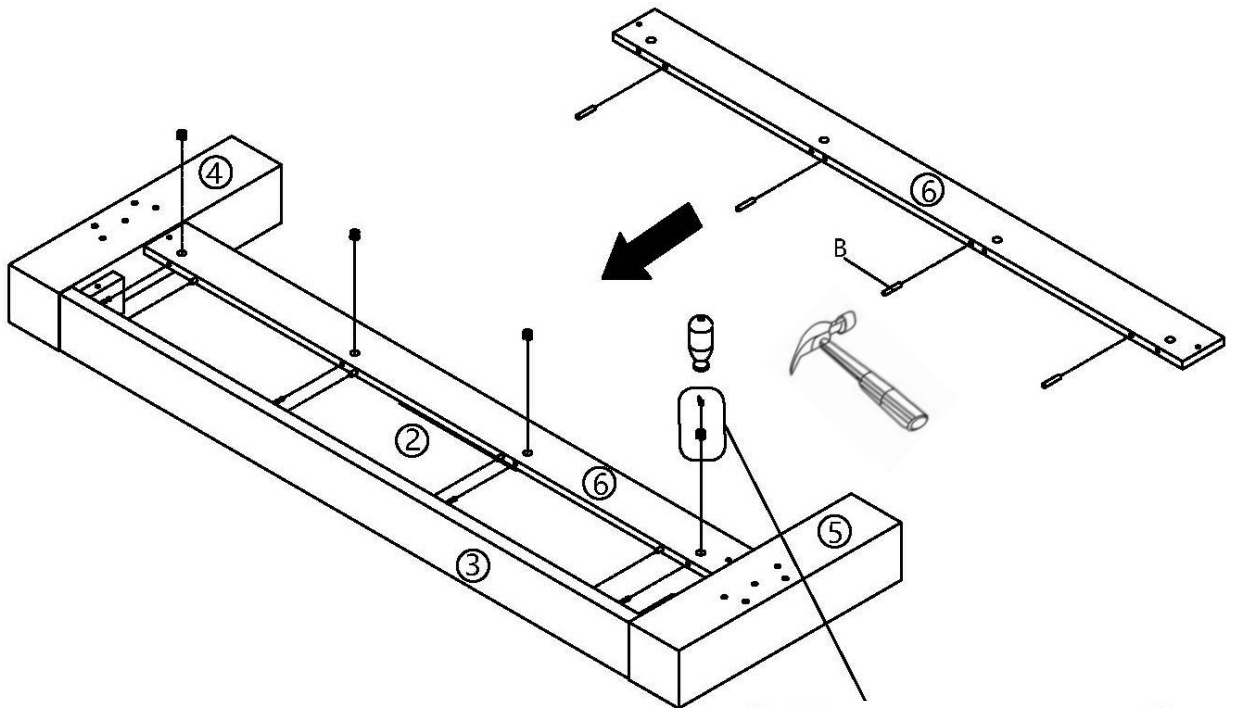

## STEP 5:

J. M4



JX1

K. M6X50mm



KX2

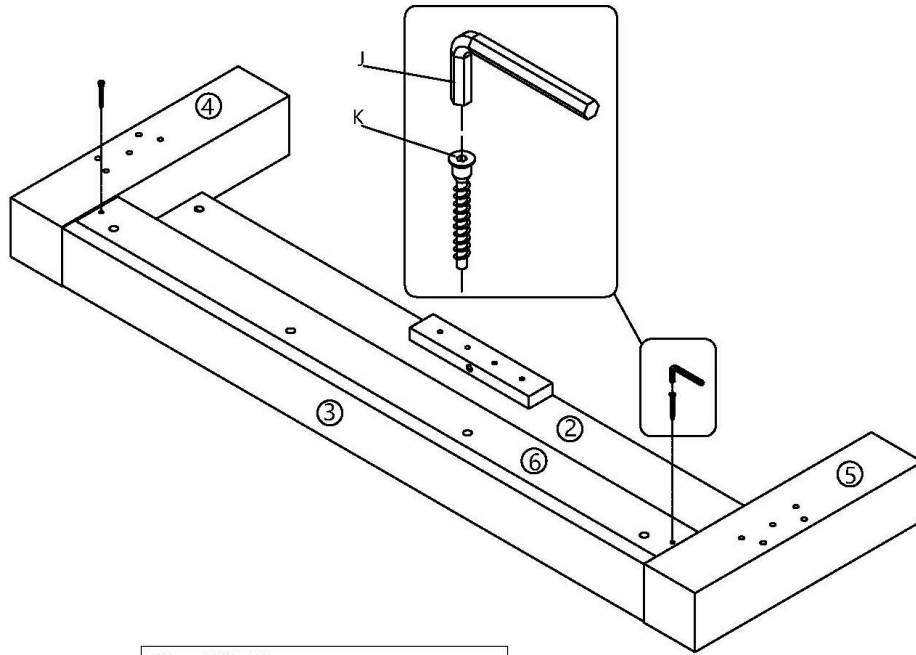

## STEP 6:

C.  $\phi 8 \times 40 \text{mm}$



CX 19

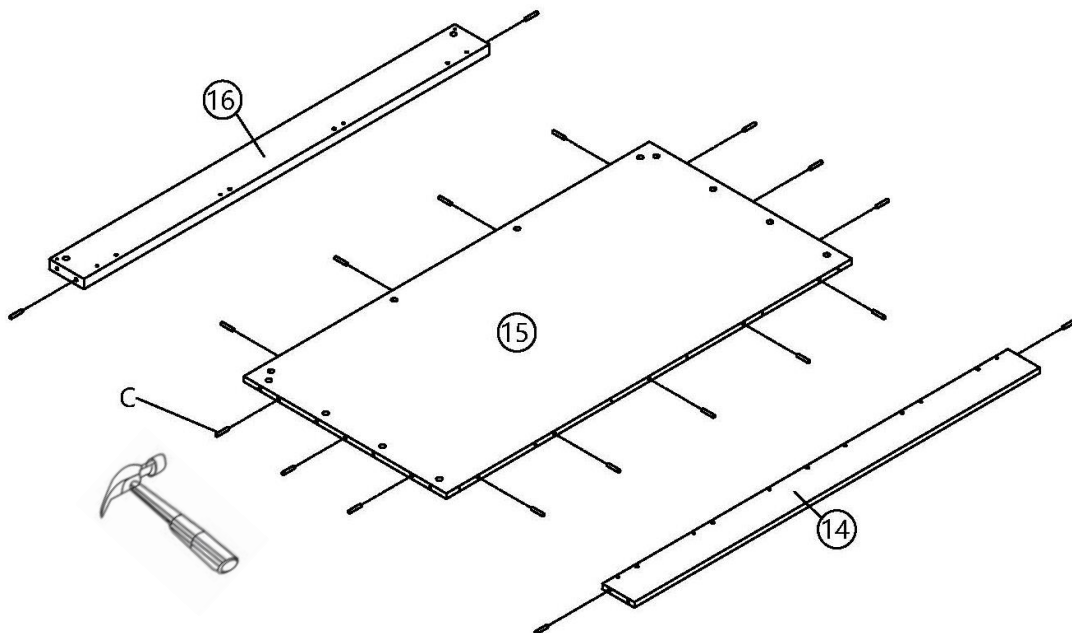



# STEP 7:

A.  $\phi 15 \times 12$



AX4

B. M7X53mm

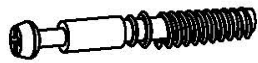

BX4

O.



OX2

P. M4X15



PX2

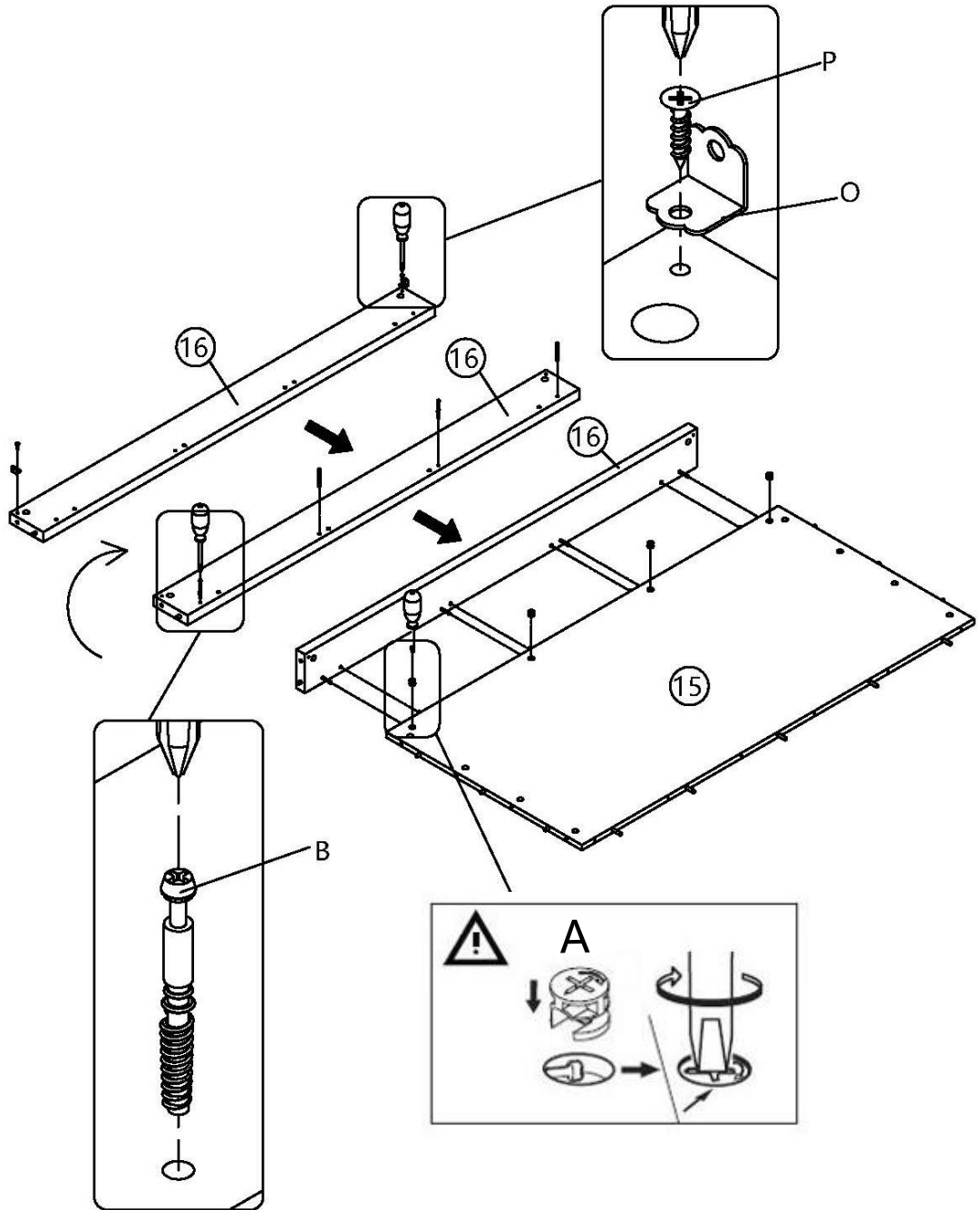

## STEP 8:

E. M5X40mm



EX6

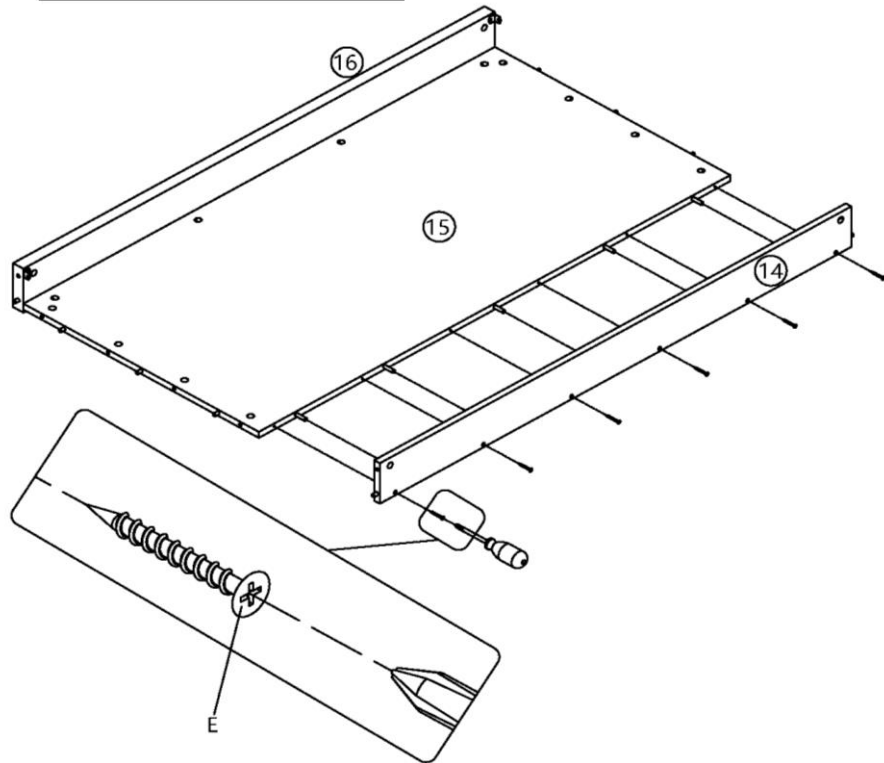

## STEP 9:

C.  $\phi 8 \times 40$ mm



CX16

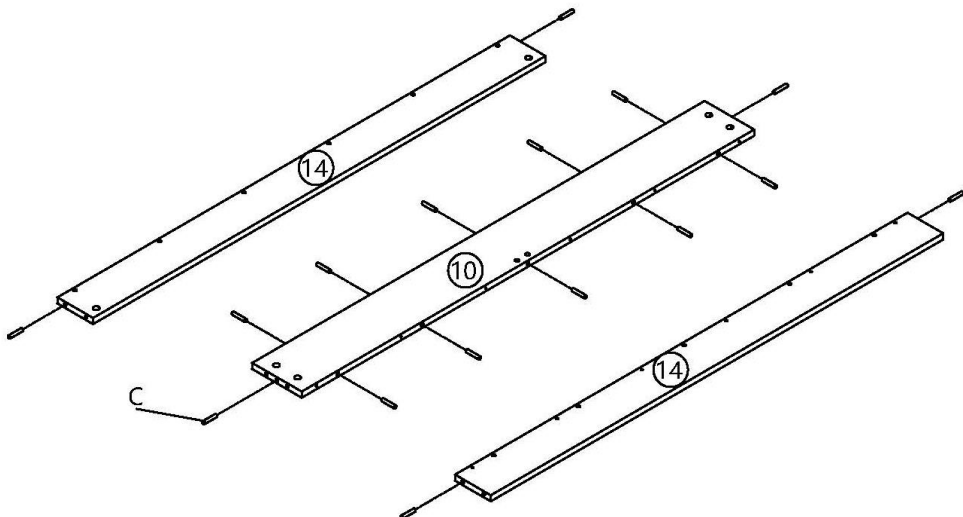

# STEP 10:

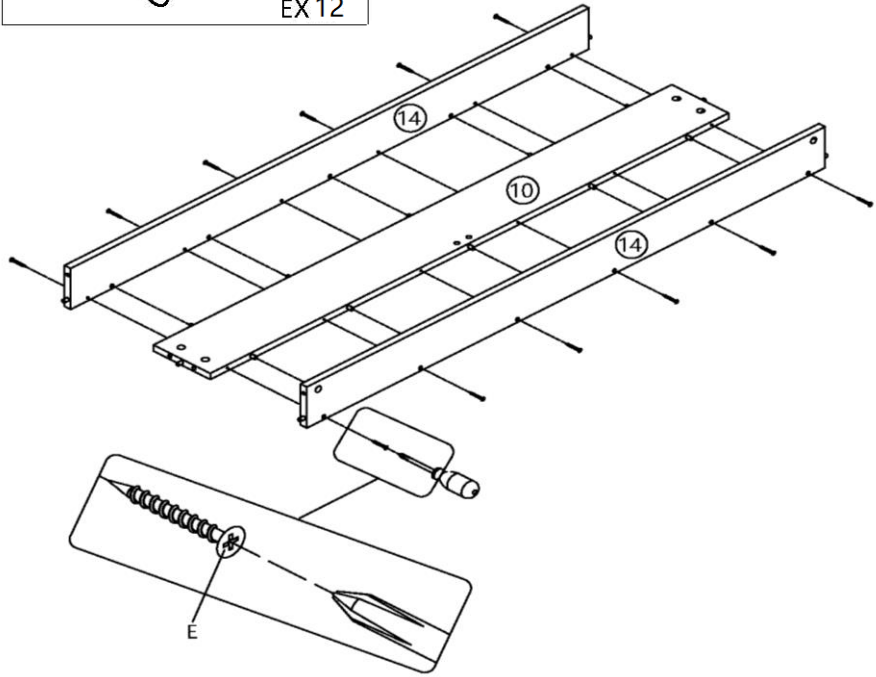
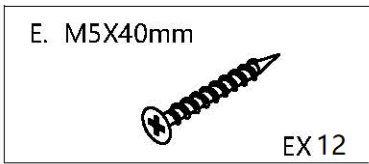

# STEP 11:

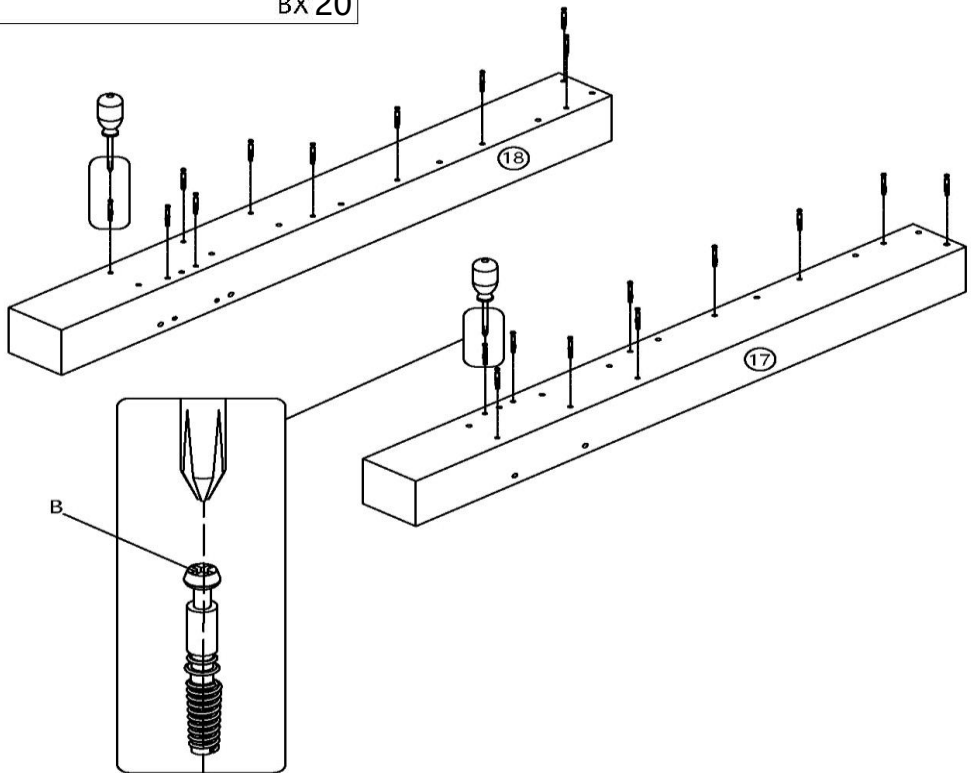
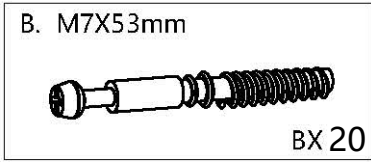

# STEP 12 :

A.  $\varnothing 15 \times 12$



AX 20

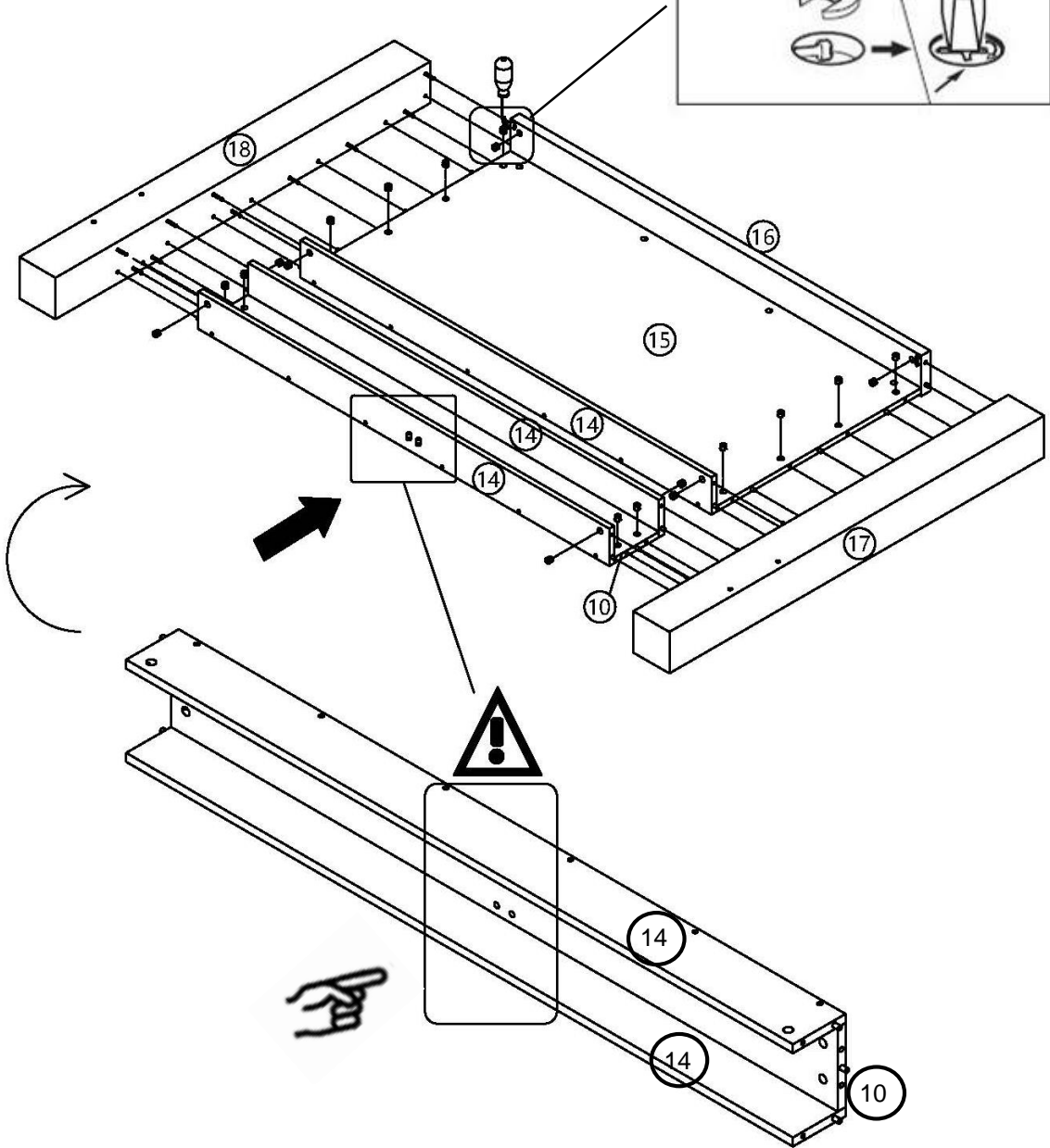
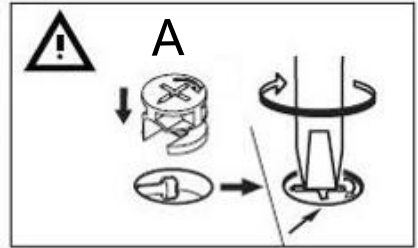

### STEP 13 :

P. M4X15



PX2

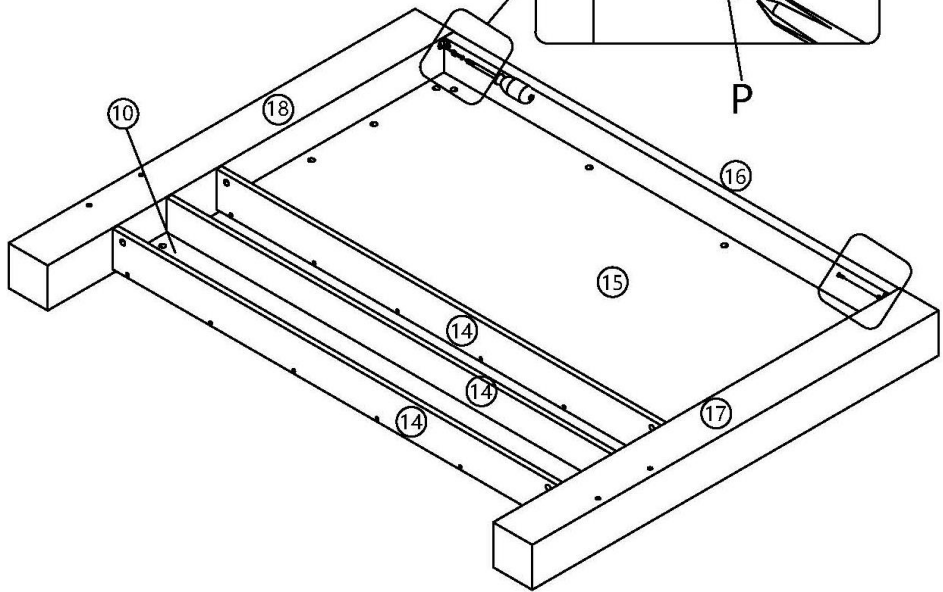
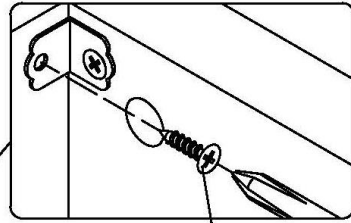

### STEP 14 :

G. M6X40mm

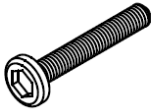

GX2

H.

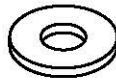

HX2

J. M4



JX1

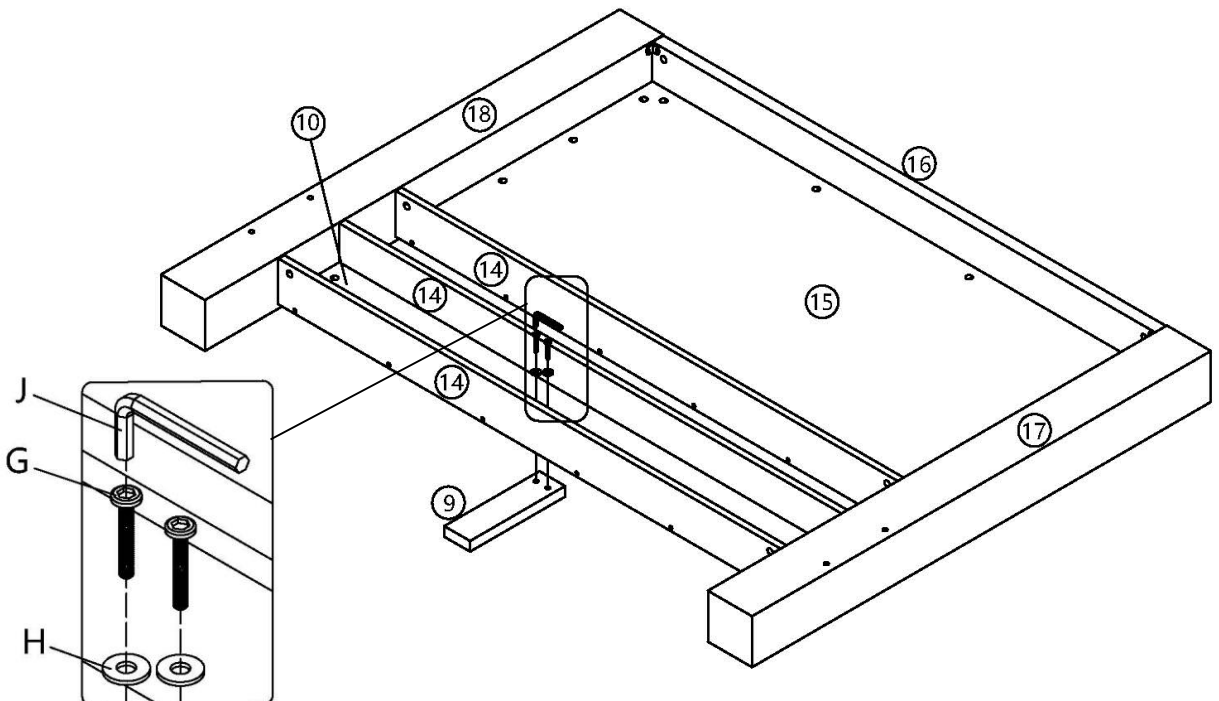

# STEP 15:

C.  $\varnothing 8 \times 40 \text{mm}$



CX 8

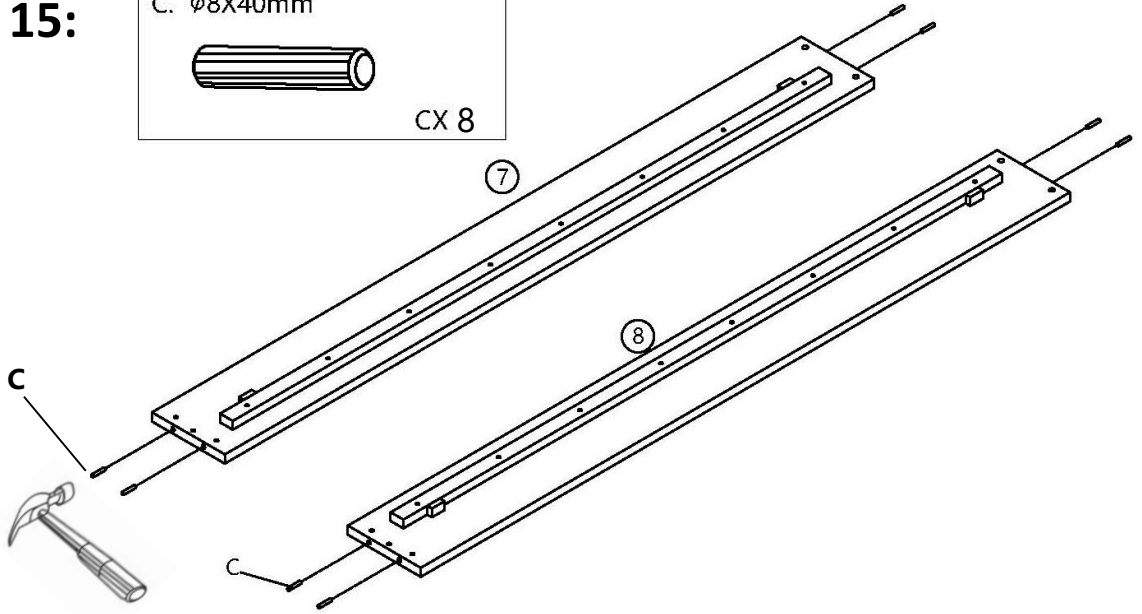

# STEP 16 :

F. M6X20mm



FX6

H.



HX6

I. L150

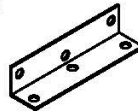

IX2



J. M4

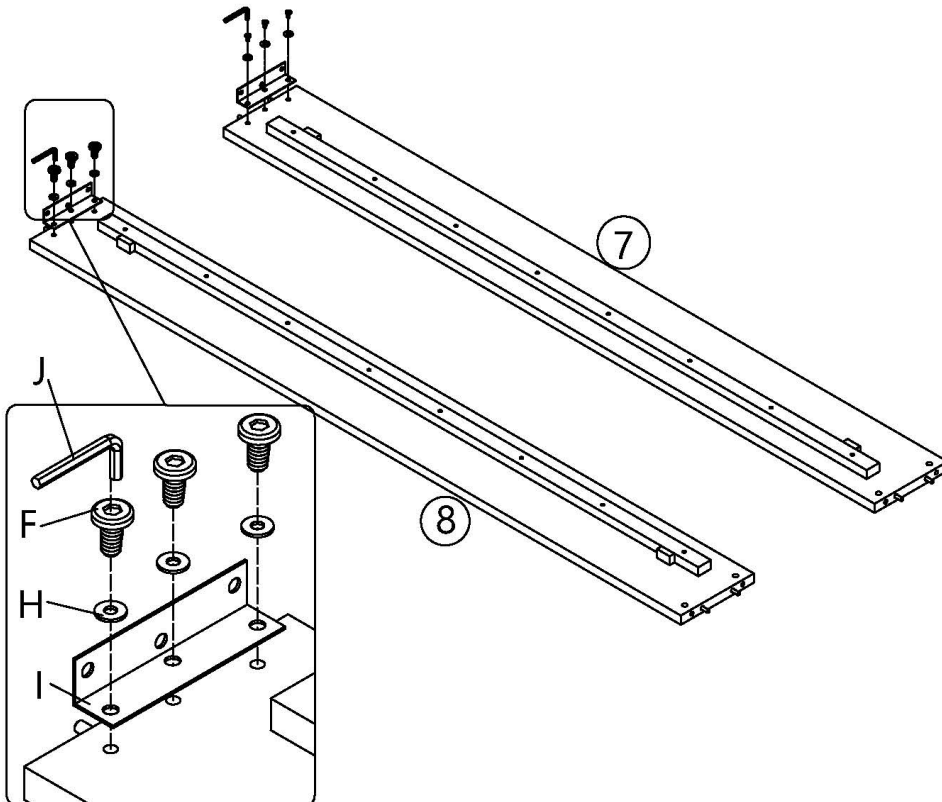

JX1



# STEP 17 :

F. M6X20mm  FX6	H.  HX6	J. M4  JX1
--	--	--

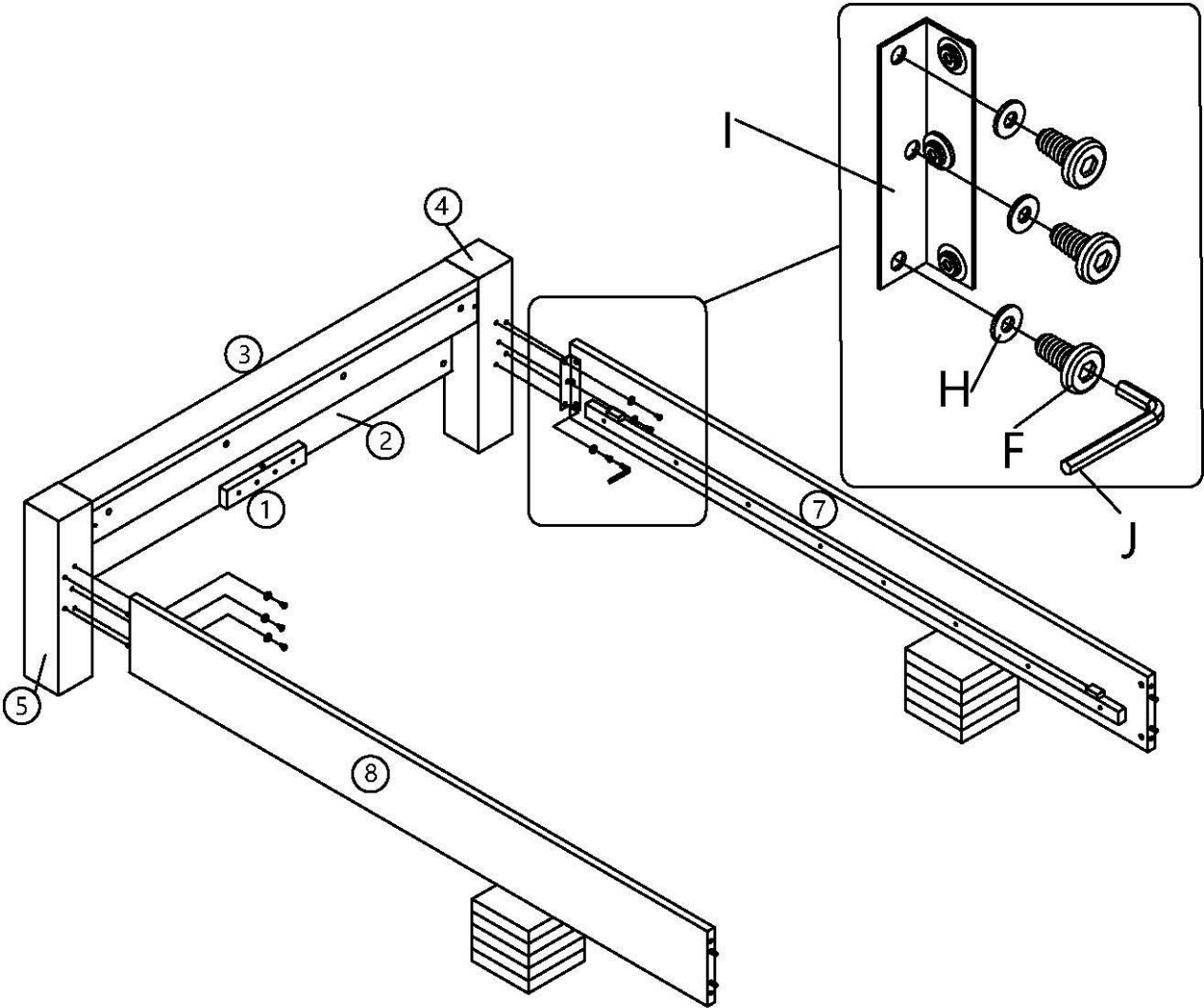

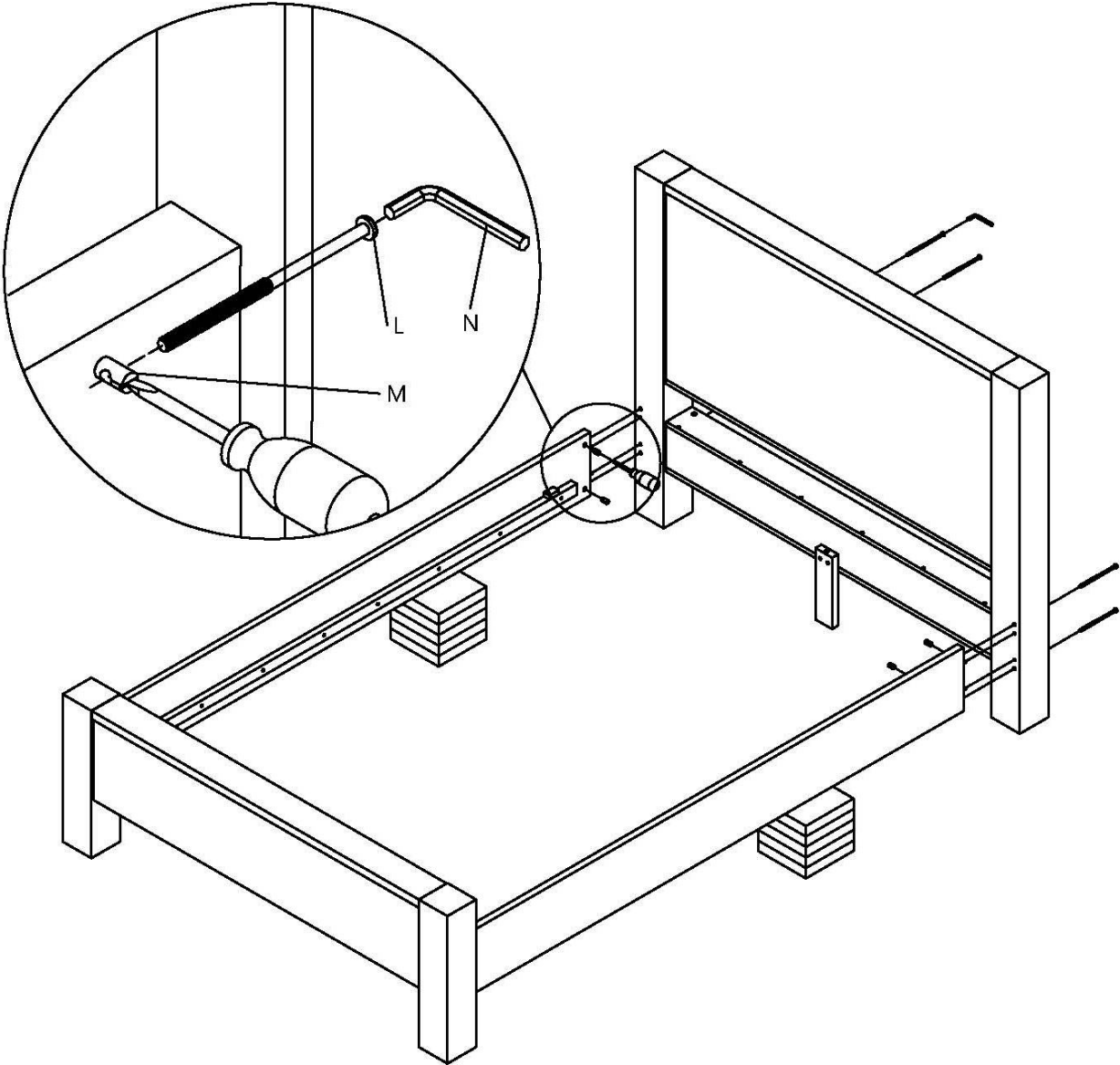
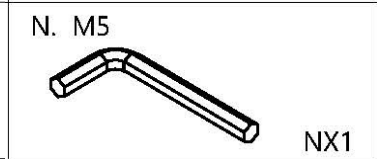
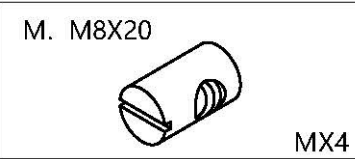
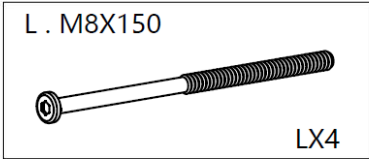

# STEP 18 :



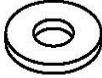

# STEP 19 :

G. M6X40mm  GX2	H.  HX2	K. M6X50mm  KX2	J. M4  JX1
--	--	--	---

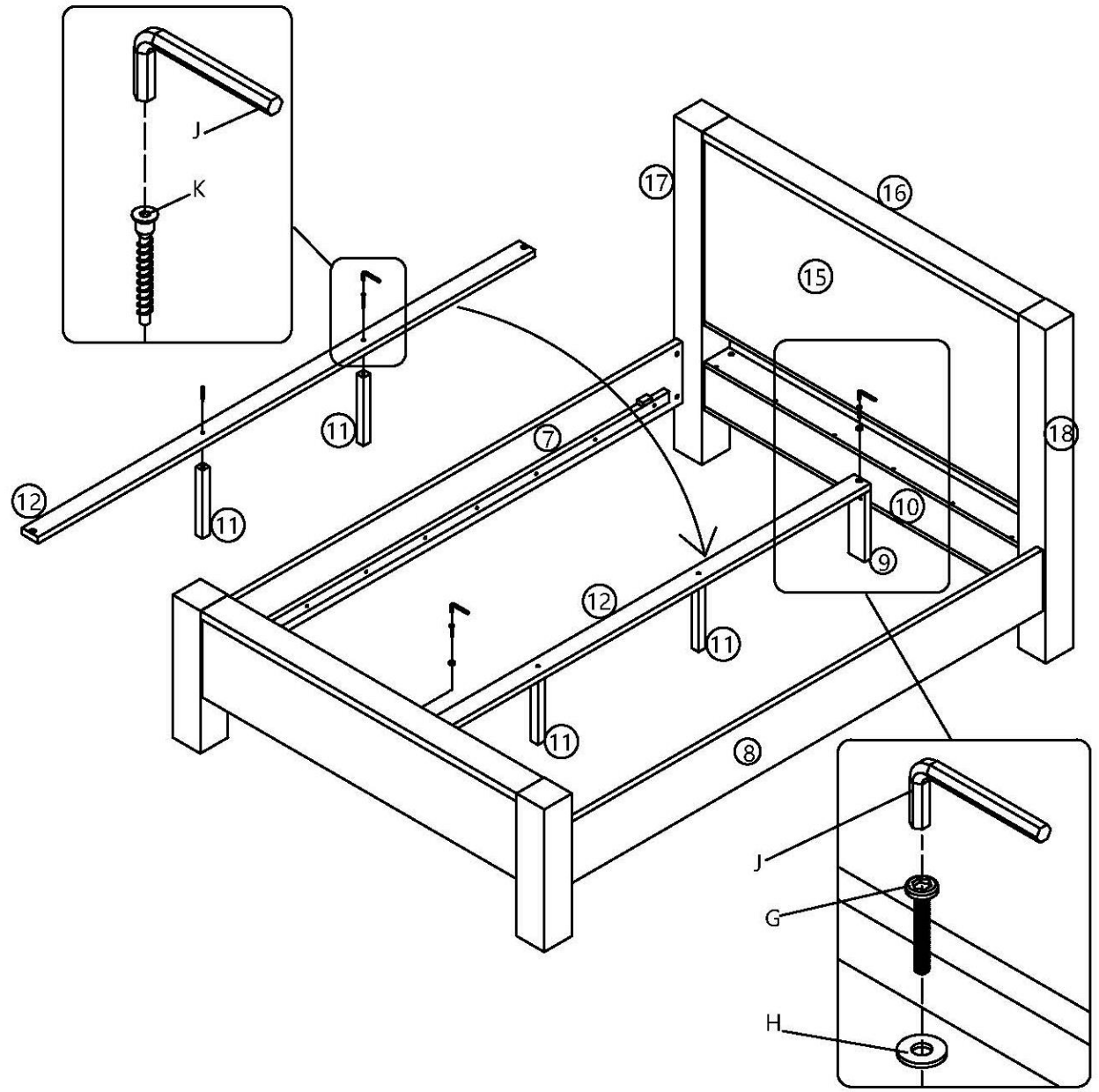

# STEP 20:

D. M5X30mm



DX9

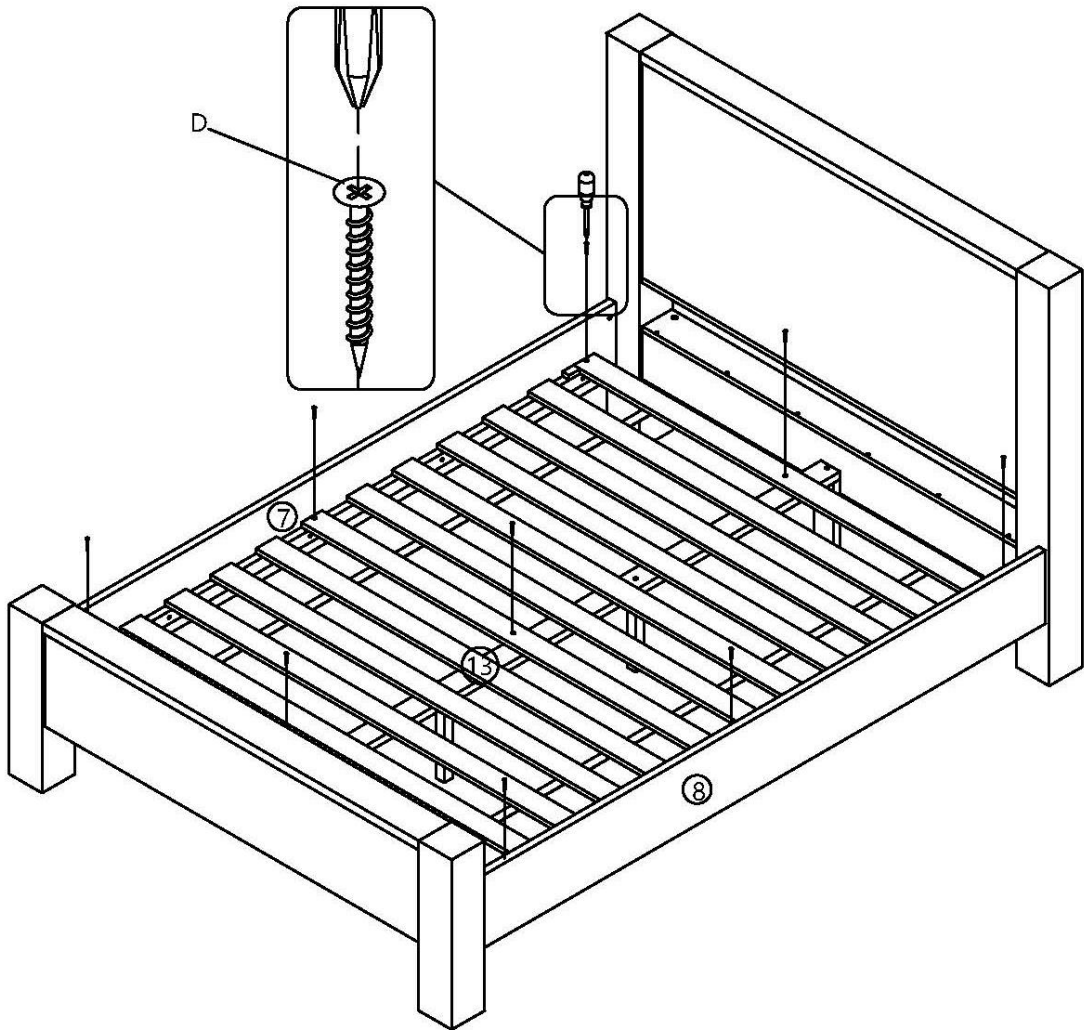

ASSEMBLY IS COMPLETE

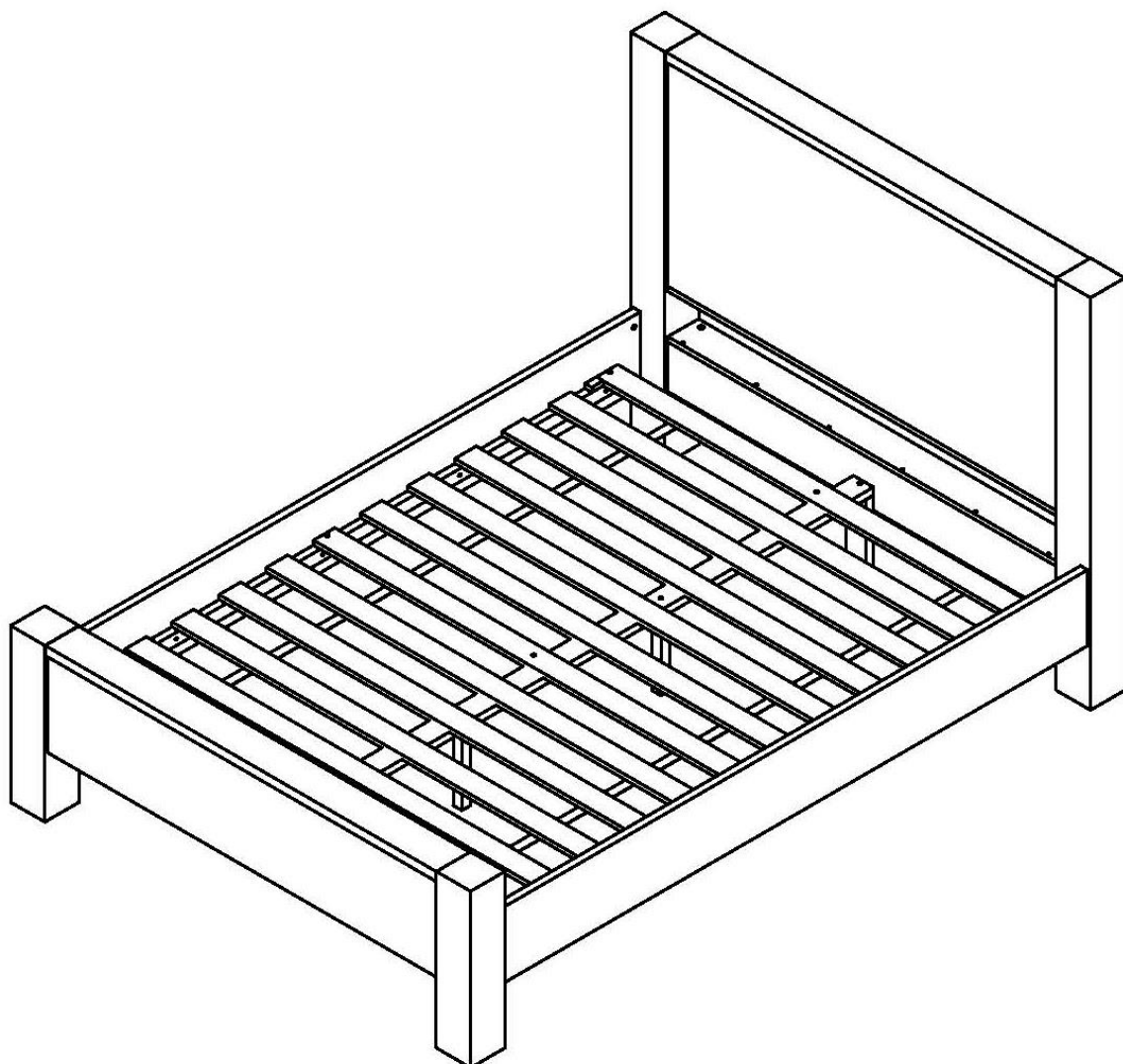

To protect your furniture, we suggest the following:

- Avoid placing your furniture in direct sunlight.
- Do not place furniture directly under windows.
- Do not place sharp materials (knife, fork, etc.) directly onto your furniture as sharp material may scrape and damage the finish.
- Do not place material with high temperature directly onto the surface of your furniture.
- Clean up spills quickly. Water left over a prolonged period of time may cause damage. Alcohol, perfume, nail polishes, aftershave and some medication may cause severe finish damage if not cleaned immediately.
- Use a clean, soft, dry, lint free absorbent cloth to clean your furniture. Do not use any detergent as they may contain ingredients that may react and damage the finish.

NOTE: If the above care advise is not adhered to your product warranty may become void